

HORIZONTAL-VERTICAL TRANSPORT SYSTEM “BALBI STR. AND DOGALI ROAD”

CLIENT: Azienda Mobilità e Trasporti S.p.A.

LOCATION: Genoa - Italy

PROVIDED SERVICE: Definitive and executive project of the car and grip.

VALUE OF THE WORKS: € ~ 2.400.000

TIME PERIOD OF CONSTRUCTION: 2004

TIME PERIOD OF SERVICE PERFORMANCE: 1998



Passage phase from the vertical lift to the horizontal line



Switch – transition curve



Lift entrance

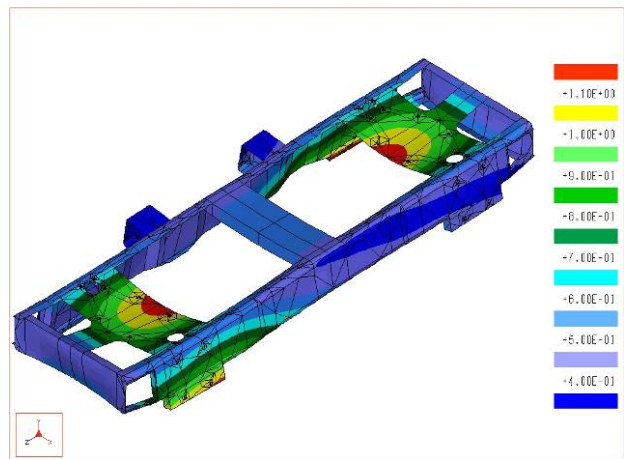

FEM - Model

RISE OF THE ELEVATOR SHAFT:	Horizontal length in Tunnel	235 m
	Rise of the elevator shaft	69 m
	Transport capacity	417 p/h
	Max speed hor. section	4.5 m/s
	Max speed vert. section	1.6 m/s
	Cabin capacity	23 pers.

OTHER INFORMATION: